

mxCONTROL Multifunction Controller



Type 8620 can be combined with...



Type 7800

Digital dosing pump



Type 8645

Extended I/O
FreeLINE



Type 8035

INLINE
Paddlewheel
Flowtransmitter



Type 8010

Flow switch



Type 8223

Inductive Conductivity
transmitter



Type 6213

on/off Brass
Solenoid valve

The mxCONTROL multifunction controller, is a microprocessor controller designed to automate the control of process variables within a water treatment system (e.g. boiler, cooling tower or Reverse Osmosis system). Sophisticated electronics and state of the art control algorithms ensure that optimum process control is maintained at all times, with minimal operator intervention.

The controller is capable of processing numerous combinations of analog and digital in- and outputs. Combined with an easy to read large graphic display backlight in three languages, F, G, E. Other languages on demand.

The controller is highly software based. It can easily be configured/parameterized using a PC tool and SD card or USB interface. Alternatively, the optional Ethernet interface can be used to configure and to parameterize the controller. Local manual parameterizing of the controller can also be achieved via the five soft-touch keys.

The controller is delivered with the SD Card containing sample configuration files and Instruction Manuals.

There are 3 levels of Man-machine interface. Open access, Operator Only Access, Specialist Access.

- Data and event logging
- One controller hardware with dozens of configuration possibilities quickly downloaded via SD card (supplied) or via USB interface
- Ethernet or modem communication with email or call event notification & numerous input/output control signals

Technical data

General details of the device

Enclosure	With sealed keypad and display
Enclosure outer dimensions L x W x H	230 x 204 x 119 mm without cable glands
Enclosure material	PC (UL94) with transparent door and key
Weight	1.8 kg
Degree of protection	IP 65 with door closed and properly sealed cable glands, waterproof according to NEMA 4X, additional cover of USB port and SD card slot
Graphic display, large and backlit	128 x 64 dots, two colored (blue and white)
Keypads for manual operation	5 keys for user inputs
Operating temperature	0 ... +50 °C
Storage temperature	-20 ... +60 °C

Electrical details

Mains voltage (power supply)	100 ... 240 V AC, 50/60 Hz, no adjustment necessary
Power consumption (of mxCONTROL device)	Max. 35 W (incl. sensor supply at Instrumentation Supply part)
Total power consumption (using the internal power distribution)	Max. 2400 W (at 240 V AC) or max. 1100 W (at 110 V AC) incl. connected actuators at Power Supply part
Total input current I _{in} (using internal power distribution)	Max. 10 A
Total output current I _{out} (using internal power distribution)	< 10 A (incl. device power consumption of 35 W)
Instrumentation supply for sensors / transistor outputs	24 V DC (±5 %), max. 1.04 A (25W), short circuit and overload protected

Technical data, cont.	
Fuse for device protection (Instrumentation)	Internal: electronic fuse, recovers automatically after fault condition is removed
Fuse for relays outputs	Relay outputs to be fused in external installation according to actuators
Inrush current (typ.)	Cold start: 30 A / 230 V AC
Electrical connections	
Electrical connection power supply	Hardware version 1: Screw terminals, grid 5.08 mm, for wire gauges 0.14 ... 1.5/2.5 mm ² (AWG 26...14) Hardware version 2: Spring type terminals, grid 5.0 mm, for wire gauges 0.2 ... 2.5/4.0 mm ² (AWG 24...12)
Electrical connection instrumentations supply	Hardware version 1: Screw terminals, grid 3.81 mm, for wire gauges 0.14 ... 1.0/1.5 mm ² (AWG 26...16) Hardware version 2: Spring type terminals, grid 3.5 mm, for wire gauges 0.2 ... 1.5 mm ² (AWG 24...16)
Cable glands and cables	Hardware version 1: 9 x M16 (PG9) 5 ... 6.5 mm cable 1 x M32 (PG21) 5 ... 6 mm cable (5x) Hardware version 2: 4 x M16 (PG9) 5 ... 6.5 mm cable 2 x M16 (PG9) 6 ... 9.5 mm cable 3 x M20 (PG13) 9 ... 13.5 mm cable 1 x M32 (PG21) 5 ... 6 mm cable (5x) Cable diameters shown above are in reference to the outer diameter. The cable glands of the bottom row are equipped with sealing bolts Thermal stability: 105 °C for cables at Power Supply part (cable material) 80 °C for cables at Instrumentation Supply part
Internal equipment - Inputs	
Inputs	Hardware version 1: 4 analog inputs (4 ... 20 mA or Pt100) (software-configurable) + 4 digital (on/off or Freq) inputs Hardware version 2: 4 analog inputs 4 ... 20 mA + 2 Pt100 + 4 digital (on/off or Freq) inputs + 4 digital (on/off) inputs
Analog inputs - Characteristics	
Input resistance of 4 ... 20 mA inputs	Max. 300 Ω
Measuring error of 4 ... 20 mA inputs	< 0.2 % FS
Range of Pt100 inputs	-20 ... +150 °C
Measuring error Pt100 inputs	Max. ±0.25 K 3 wire connection and software compensated wire resistance required
Digital inputs - Characteristics	
Logical values on/off inputs	1 or HIGH: 13 ... 35 V; 0 or LOW: 0 ... 4.5 V
Input resistance of on/off inputs	≥ 20 kΩ
Max. frequency	2 kHz
Duty factor frequency	1 : 1
Measuring error frequency	Max. 0.2 % FS
Input accepts signals from	Open collector; open emitter; push-pull output; hall effect; reed switch; micro switch
Internal Equipment - Outputs	
Outputs	Hardware version 1: 5 Relay outputs + 4 analog outputs 4 ... 20 mA (optional) + 4 Transistor outputs (optional) Hardware version 2: 5 Relay outputs + 2 analog outputs 4 ... 20 mA + 2 Transistor outputs
4 ... 20 mA analog outputs - Characteristics	Max. 500 Ohmic load, output resolution 10 bit (effective >9 bit)

Technical data, cont.	
Relay outputs - Characteristics	Max. 250 V AC/DC, max. 10 A, potential-free, two-way SPDT contacts, max. 2500 VA (AC), max 40 W Ohmic load (DC), 3 million switching cycles at 1 A, 10 million switching cycles at 0 A
Transistor outputs - Characteristics	24 V DC, Switching capacity each max. 16 W, pnp, max. 2200 Hz
Further internal equipment	
Micro-controller core	32 bit with integrated flash memory
Slot for SD card (memory card)	Can be used for data logging, up- and download of configuration and parameter files
Clock	Real-time clock with calendar
Battery back-up for real-time clock	Lithium battery CR2032, exchangeable, approx. 10 years service life
Communication	
SD card	SD card capacity: minimum 64 MB, maximum 2 GB, formatted with FAT16 file system
Up-/download of configuration data and parameters	Via USB or SD card
Data-logging	On SD card
Firmware update	Via USB
USB slave interface	Standard USB interface for PC communication
Ethernet interface	Optional: Ethernet interface for easy diagnosis including Web Server and email option
Extension bus interface	CAN-based bus for connection of extension units (e.g. I/O extensions)
Controller structure	
Number of control loops	Max. 8 active control loops
Controller outputs/Module outputs	1) On/off 2) Pulse frequency modulated (fixed pulse length, variable pauses) 3) Pulse width modulated 4) Analog
Sample period	Approx. 50 ms (with 1...4 active control loops); Approx. 100 ms (more than 4 active control loops)
User configuration	Cascade control possible; inputs, outputs and control function designations can be changed via configuration file
Norms and standards	
Environment standards	IEC 68
EMC standards	EN 61000, EN 55011
CE mark	Applicable tests resulting in CE mark
UL/CSA	UL pending

Ordering chart (other versions on request)

Electrical connection	Hardware version	Inputs					Outputs			Communication	Ethernet	Enclosure version	Item no.
		Analog inputs 4 ... 20mA	Pt100 inputs	Analog inputs 4-20 mA or Pt100	Digital (on/off) inputs	Digital (on/off or Freq) inputs	Analog outputs 4-20 mA	Relay outputs	Transistor outputs				
Screw terminals	1	-	-	4	-	4	-	5	-	-	A	188 133	
		-	-	4	-	4	4	5	4	X	A	188 136	
Spring type terminals	2	4	2	-	4	4	2	5	2	-	B	188 137	
		4	2	-	4	4	2	5	2	X	B	188 138	

Dimensions [mm]

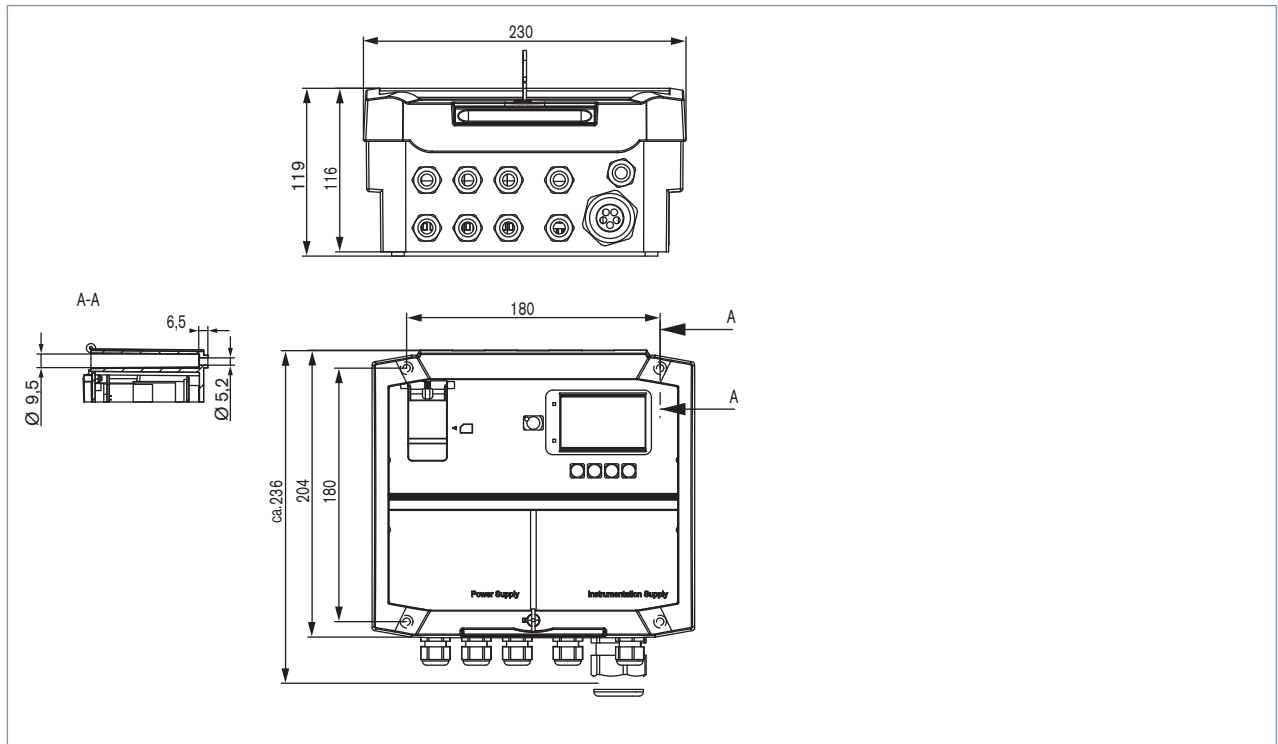

Enclosure versions

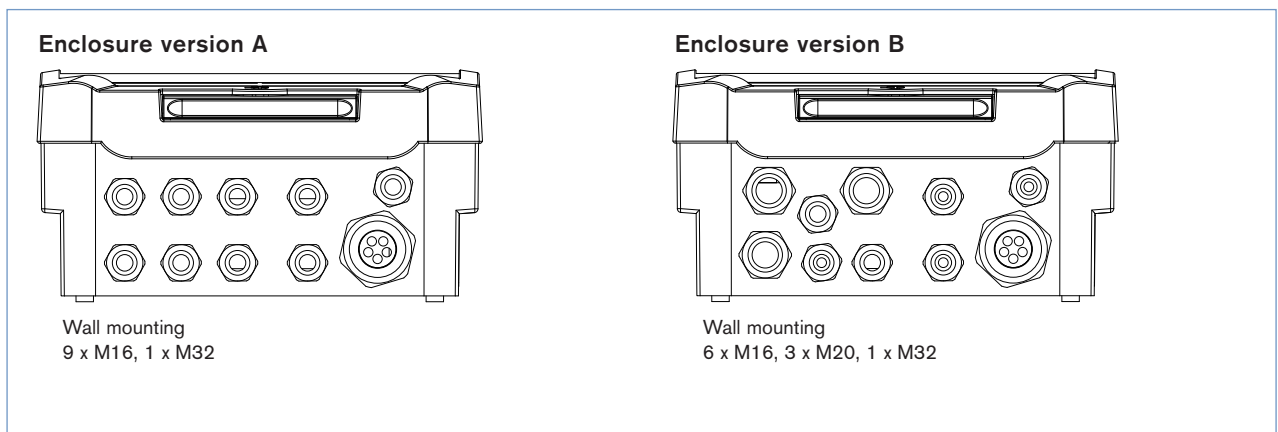

Hardware structure

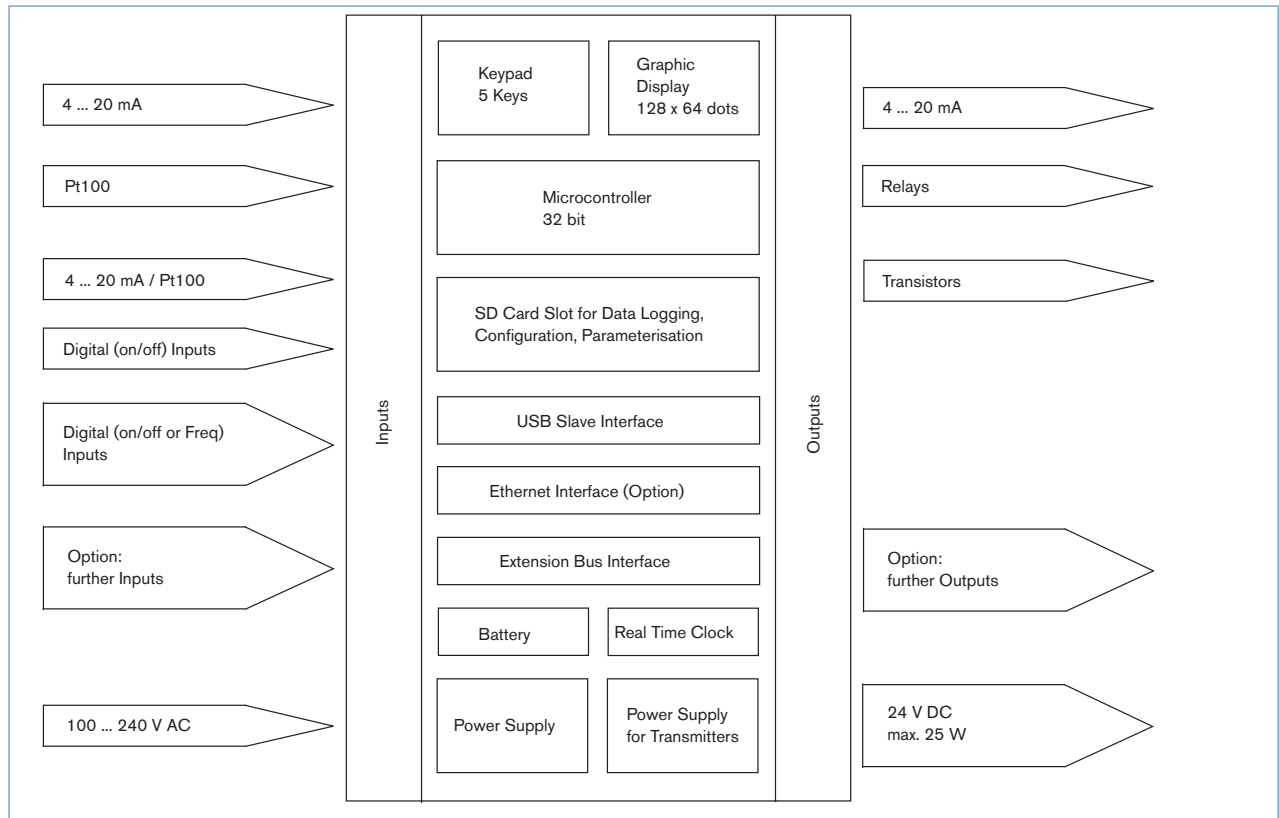

Hardware versions

		Hardware version 1	Hardware version 2
Inputs	Analog 4 ... 20 mA	–	4
	Analog Pt100	–	2
	Analog 4 ... 20 mA / Pt100	4	–
	Digital (on/off)	–	4
	Digital (on/off or Freq)	4	4
Outputs	Analog 4 ... 20 mA	4 (optional)	2
	Relay	5	5
	Transistor	4 (optional)	2

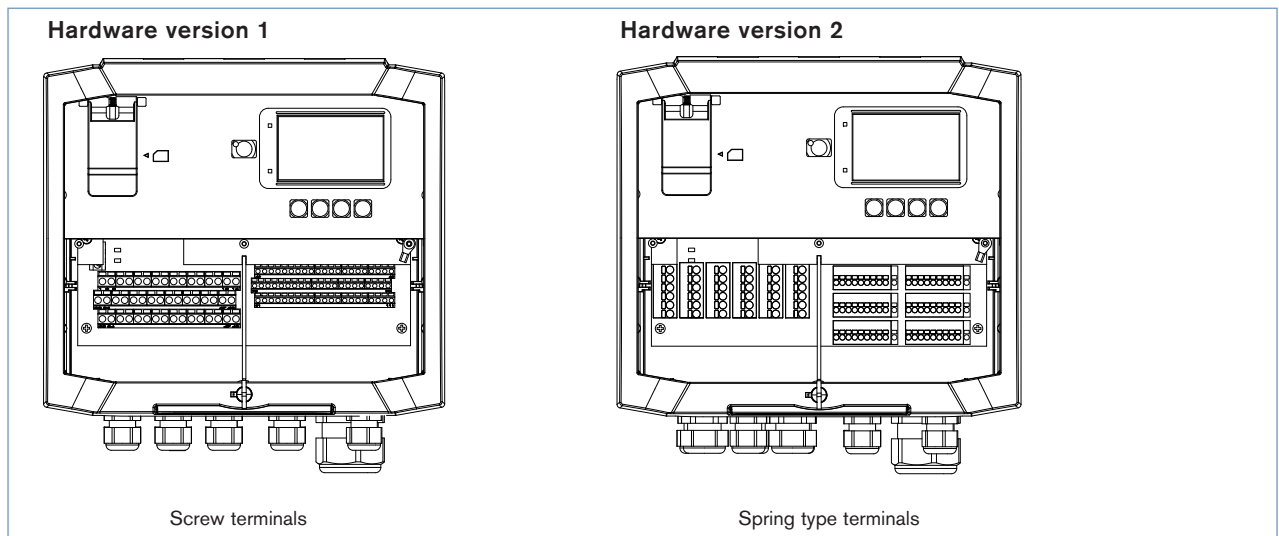

Process diagram

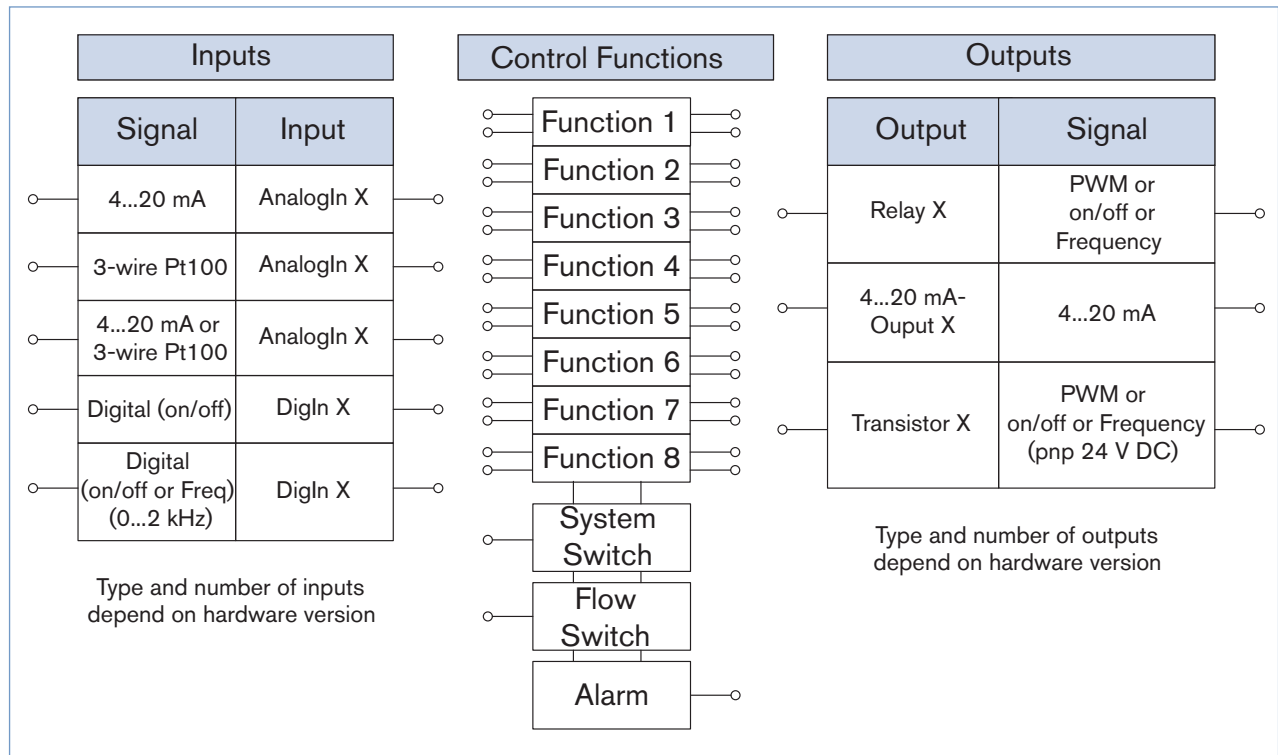

Easy configuration / parameterization using a PC tool

Input configuration including scaling, filtering, alarm limits, engineering units

Selection of control functions and input - output - assignment

Output configuration

Control Functions

General PID control

PID process controller for fixed value, subsequent value or cascade control

Conductivity control

On/off or PI control - continuous dosing through pulse frequency modulation (PFM), PWM or 4-20mA analog output, automatic or manual drain

Corrosion display

No controller function, only display of measuring values; impact on general alarm output

pH control

PI control - continuous dosing through pulse frequency modulation (PFM), PWM or analog output

Module for dosing of oxygen scavenger media

Proportional dosing for flow and oxygen content depending on flow with or without temperature input

Chlorine / Redox Control

PI control - continuous dosing through pulse frequency modulation (PFM), PWM or 4-20mA analog output

Batch dosing

Allows batching of a chemical based on volume of water added

Biocide dosing

14-day program, 8 dosing events per channel / per day; Pre-bleed function to optimize biocide kill time

Monitor module

Display of process value

Totalizer function

Single or dual channel flow totalizer (each having two manually resettable totalizers)

PC Tool

...for easy configuration and parameterization to be downloaded from www.burkert.com

The screenshots below are part of a configuration for a 4 loop temperature control system used for cooling of an injection moulding machine.

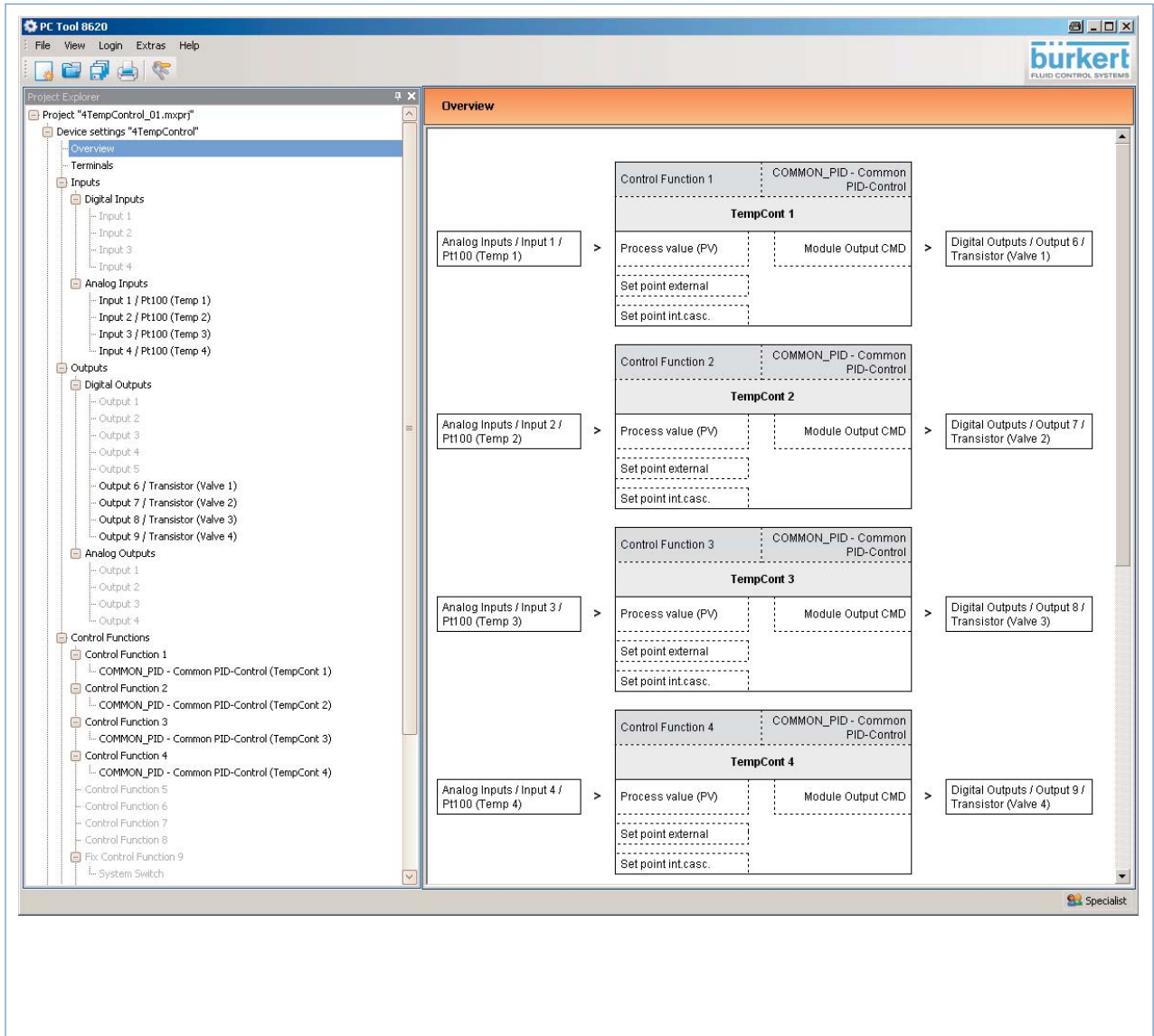

DTS 1000115642 EN Version: A Status: RL (released | freigegeben | valide) printed: 29.08.2013

PC Tool, continued

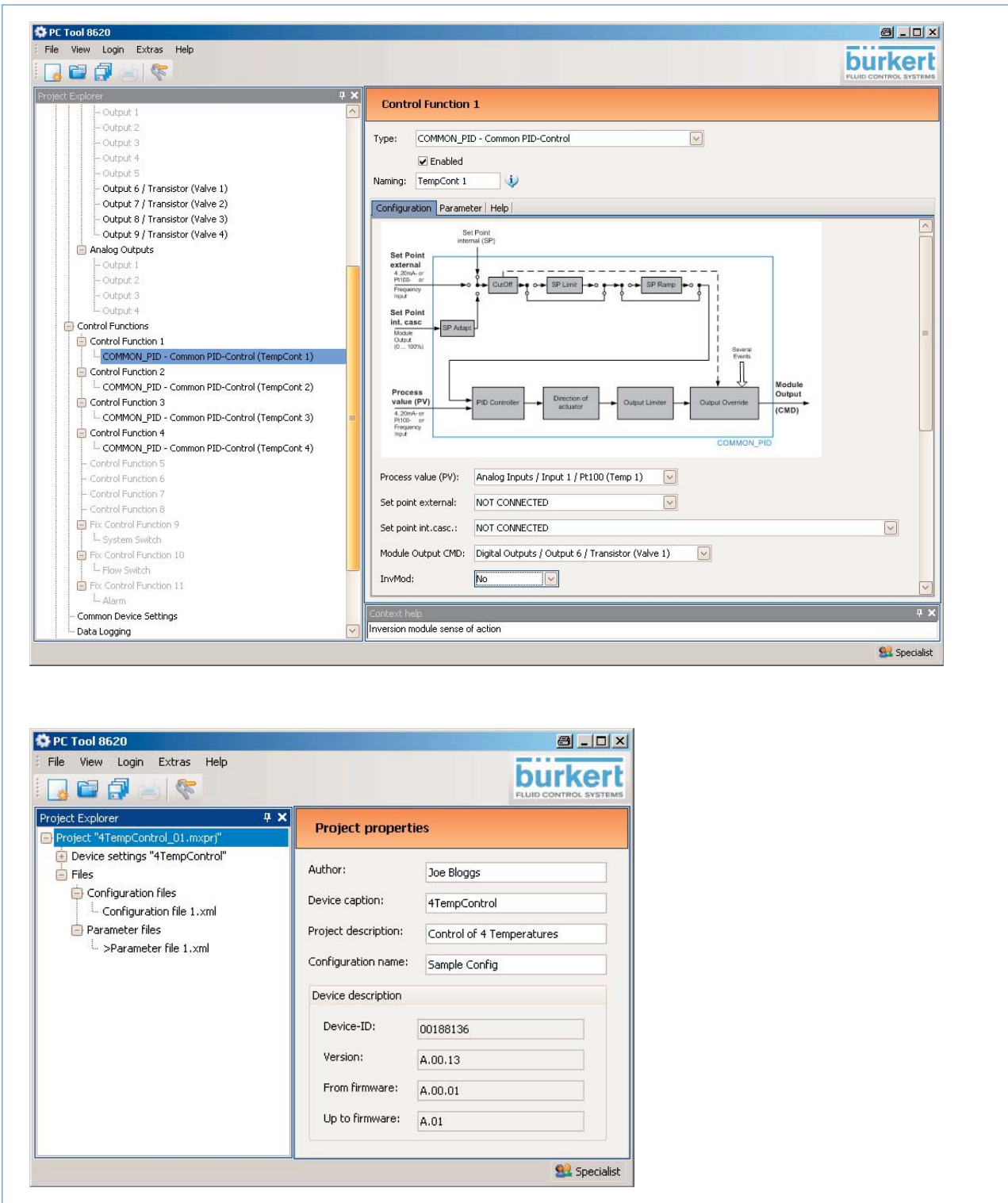

DTS 1000115642 EN Version: A Status: RL (released | freigegeben | valide) printed: 29.08.2013

To find your nearest Bürkert facility, click on the orange box →

www.burkert.com

In case of special application conditions, please consult for advice.

Subject to alteration.
© Christian Bürkert GmbH & Co. KG

0901/0_EU-en_00895037